

LED-Strip M12

Product Sheet



© 2018 Schnick-Schnack-Systems GmbH

Version September 2018: All technical data and the weight and dimension information were carefully created – errors reserved. Any colour deviations are printing-related.

We reserve the right to make changes that serve further improvement.

Quick Info

Overview technical data

Features	LED-Strip M12-250	LED-Strip M12-500
Length	250mm	500mm optionally available in the lengths: 262,5mm, 275mm, 287,5mm, 300mm, 312,5mm, 325mm, 337,5mm, 350mm, 362,5mm, 375mm, 387,5mm, 400mm, 412,5mm, 425mm, 437,5mm, 450mm, 462,5mm, 475mm und 487,5mm
LED-Pitch	12,5mm	12,5mm
Current (I_{max})	0,15A	0,3A
Colour	<ul style="list-style-type: none"> • Warm white: 2000K, 2200K, 2500K, 2700K, 3000K, 3500K • Neutral white: 4000K, 4500K • Cold white: 5000K, 5700K, 6500K • Alternative spectrums: 2700K AS, 3000K AS, 3500K AS, 4000K AS, Meat • Colours: Red, Green, Blue, Amber 	
Luminous flux*	195lm	390lm
Luminous intensity*	60cd	120cd
Channels	20	40

Overview of control options

		LED-Strip M12-250	LED-Strip M12-500	Details on page
System Power Supply 4E/ DPB Pixel-Router Pro	with DPB	160 LED-Strips per controller	80 LED-Strips per controller	15/16
	with DMX	100 LED-Strips per controller	48 LED-Strips per controller	
DPB Pixel-Router	with DPB	80 LED-Strips per controller	40 LED-Strips per controller	17
Sys One	Output XLR-4pin	25 LED-Strips per controller	12 LED-Strips per controller	18
	Output System connector red	40 LED-Strips per controller	20 LED-Strips per controller	
70W power supply with DMX		20 LED-Strips per power supply	10 LED-Strips per power supply	20

* The values are measured with a LED strip M12-250 and M12-500 in the colour temperature 6500K (further values can be found on page 8).

Introduction

FEATURES

- Generation 3 compatible
- Automatic Addressing System (Smart Link) – no addressing at the board
- Compatible with other series from Schnick-Schnack-Systems
- Free patch, colour change and scroll text control software
- Made in Germany

- High-quality LEDs
- High colour rendering index $R_a > 90$
- Best arrangement thanks to very small bins (3Step MacAdam)
- Alternative spectrums for specific object lighting
- Each LED is internally dimmable with 16-bit resolution
- Externally switchable between 8-bit and 16-bit resolution
- Wider 115° beam angle
- Custom arrangement in several colours or with lenses possible
- camera friendly dimmable
- Equal brightness despite different supply-line lengths due to integrated switching regulator
- Optimum efficiency due to state-of-the-art circuit technology

- Direct control with DMX 512-A

- Pliable, fiberglass reinforced board
- Minimal surface temperatur
- Higher contrast due to black lacquered board
- Versatile mounting options

Use

The M Series LED strips are equipped with high-quality, efficient, white or monochrome LEDs with (where possible) a colour rendering index of $R_a > 90$. Each LED can be controlled individually.

They are the ideal LED light source for all applications in which monochrome, dynamic surfaces, structures or video effects need to be realized. Thanks to the high colour rendering index, the LED strips M can also be used for illuminating.

Technology

The LED-Strip M12 can be ordered in 16 different white tones, five of them with alternative spectrums, for example for food lighting and four colours:

- Warm white: 2000K, 2200K, 2500K, 2700K, 3000K, 3500K
- Neutral white: 4000K, 4500K
- Cold white: 5000K, 5700K, 6500K
- Alternative spectrums: 2700K AS, 3000K AS, 3500K AS, 4000K AS, Meat
- Colours: Red, Green, Blue, Amber

In addition, the strip is available in 21 different lengths (250mm, 262,5mm, 275mm, 287,5mm, 300mm, 312,5mm, 325mm, 337,5mm, 350mm, 362,5mm, 375mm, 387,5mm, 400mm, 412,5mm, 425mm, 437,5mm, 450mm, 462,5mm, 475mm, 487,5mm and 500mm) in a grid of 12,5mm. The radiation characteristics of the strips can be changed using optional lenses. And, thanks to our Smart Link Technology elaborate addressing of the strips is eliminated.

The LED strips M12 belong to Generation 3 and in addition to DMX, can also read the Dynamic-Pixel-Bus protocol (DPB). By using the DPB, more LED strips per output of a system power supply are available – up to 3,072 channels. A variable transmission rate enables the best, customized balance of channel count, frame and error rate. When video signals are used, a system-wide synchronization (System Wide Sync) prevents image distortion. The system speed can therefore easily reach the 60fps update rate and switching between DMX and DPB is possible at all times.

The strip firmware can be updated from a central point via the network with the System Power Supply 4E, which also means that future standards or developments can be supported. Each Stripe sends status information such as temperature, data error rate, input voltage or LED defects back to the control system and therefore enabling a problem-free remote diagnosis.

When using diffusers, the distance needed to create a homogeneous surface depends on the material. There should be at least 3cm from the topside of the LED to the diffuser. The LED strips are mounted with board holders.

Control

Power supply and control takes place via the System Power Supply 4E, the DPB Pixel-Router, the DPB Pixel-Router Pro or the Sys One. For small installations also via a corresponding power supply with a DMX XLR-5pin connector. Pixel-accurate control of the M Series LED strips can be achieved with lighting boards, media servers or with our Pixel-Gate video converter via the Ethernet interface of the controllers.

Mechanical data

Features	LED-Strip M12-250	LED-Strip M12-500
Length	250mm	500mm optionally available in the lengths: 262,5mm, 275mm, 287,5mm, 300mm, 312,5mm, 325mm, 337,5mm, 350mm, 362,5mm, 375mm, 387,5mm, 400mm, 412,5mm, 425mm, 437,5mm, 450mm, 462,5mm, 475mm und 487,5mm
LED-Pitch	12,5mm	12,5mm
Number of LEDs (for standard length)	20	40
Pin connection and -colour	System connector red	System connector red
Safety class	IP00	IP00
Weight	17,3g	32,3g



LED-Strip M12-250 (front view)*



LED-Strip M12-250 (rear view)*



LED-Strip M12-500 (front view)*



LED-Strip M12-500 (rear view)*

* scaled illustration

CAD drawing*

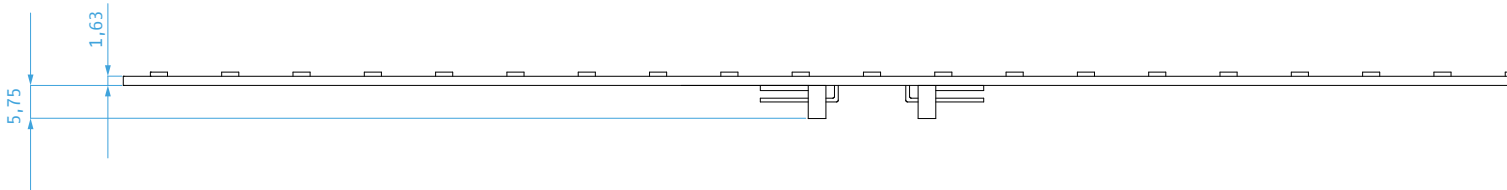
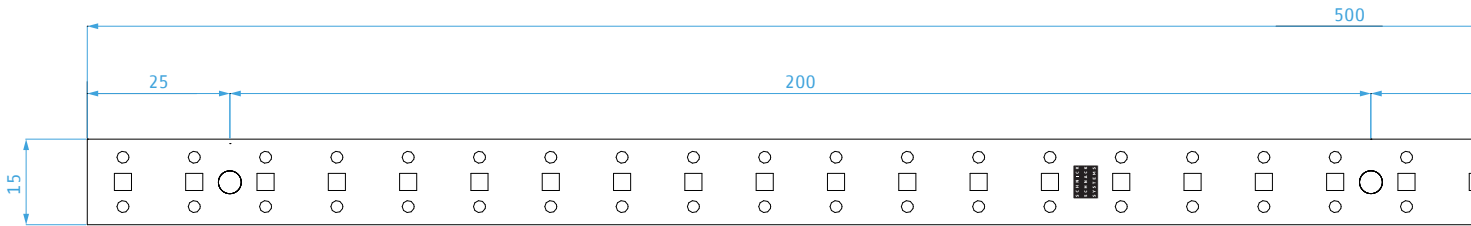
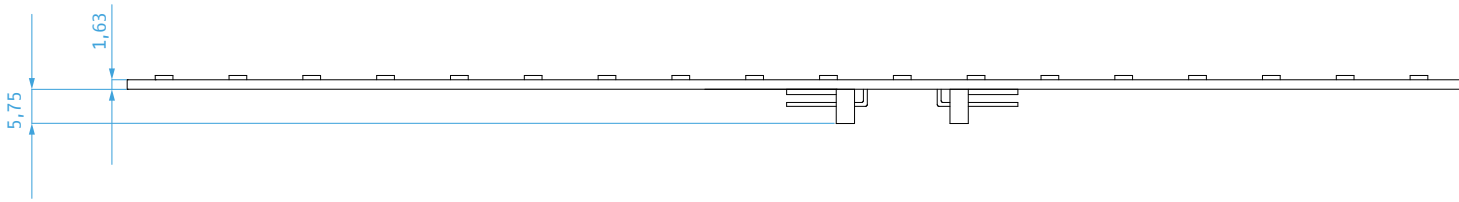
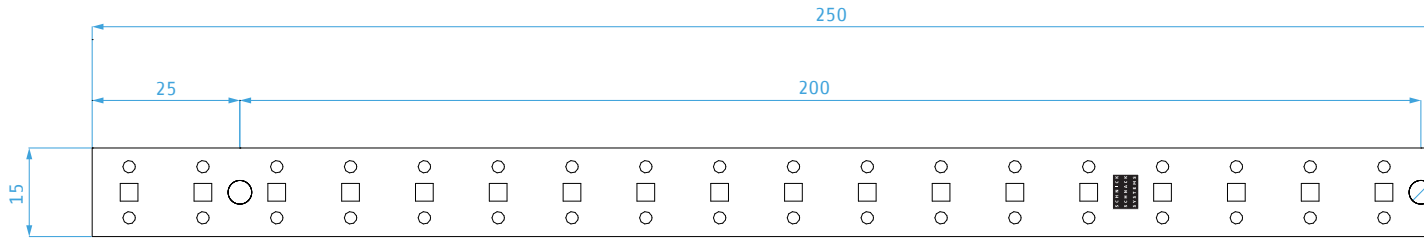

* without scale / all units in mm

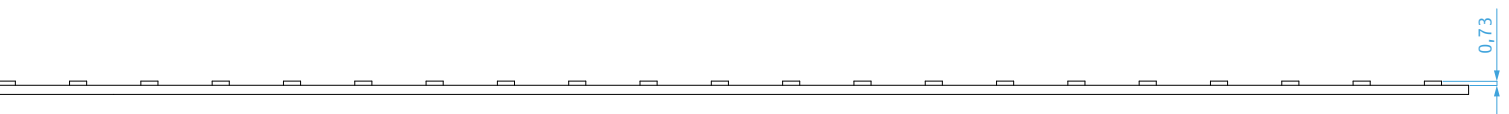
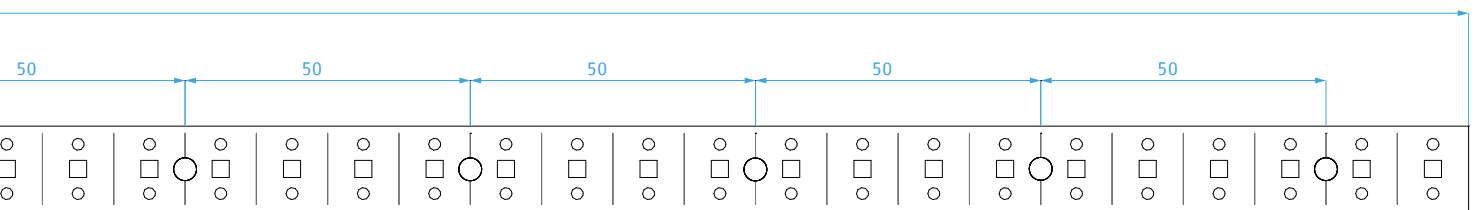
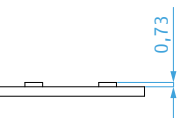
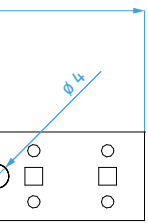

Optical data

	Emission angle	Colour	Luminous flux*	Efficiency (at 20V)	Colour Rendering Index R _a	Luminous intensity**
LED-Strip M12-250 MK3	115°	2000K	165,5lm	58,7lm/W	84,4	59cd
		2200K	167lm	59,2lm/W	85,2	59cd
		2500K	192,5lm	68,0lm/W	85,4	68cd
		2700K	183,5lm	64,6lm/W	93,8	64cd
		2700K AS	148lm	52,1lm/W	73,1	56cd
		3000K	194lm	68,3lm/W	94,2	68cd
		3000K AS	155,2lm	54,8lm/W	74,1	58cd
		3500K	196lm	69,0lm/W	95,5	68cd
		3500K AS	168lm	59,4lm/W	76,1	62cd
		4000K	207lm	73,1lm/W	94,8	72cd
		4000K AS	174lm	61,5lm/W	77,3	64cd
		4500K	207,6lm	73,1lm/W	93,6	72cd
		5000K	206lm	72,5lm/W	95,2	72cd
		5700K	205lm	71,9lm/W	96,3	71cd
		6500K	195lm	69,1lm/W	95,9	68cd
		Red	96lm	34,0lm/W		34cd
		Green	252,2lm	89,4lm/W		90cd
		Blue	65,2lm	23,0lm/W		23cd
		Amber	296lm	105,0lm/W		108cd
		Meat	176,4lm	62,6lm/W	72,4	65cd
LED-Strip M12-500 MK3	115°	2000K	331lm	58,7lm/W	84,4	117cd
		2200K	334lm	59,2lm/W	85,2	117cd
		2500K	385lm	68,0lm/W	85,4	136cd
		2700K	367lm	64,6lm/W	93,8	128cd
		2700K AS	296lm	52,1lm/W	73,1	111cd
		3000K	388lm	68,3lm/W	94,2	136cd
		3000K AS	311lm	54,8lm/W	74,1	115cd
		3500K	392lm	69,0lm/W	95,5	135cd
		3500K AS	336lm	59,4lm/W	76,1	125cd
		4000K	414lm	73,1lm/W	94,8	143cd
		4000K AS	348lm	61,5lm/W	77,3	128cd
		4500K	415lm	73,1lm/W	93,6	144cd
		5000K	412lm	72,5lm/W	95,2	143cd
		5700K	410lm	71,9lm/W	96,3	141cd
		6500K	390lm	69,1lm/W	95,9	136cd
		Red	192lm	34,0lm/W		68cd
		Green	504lm	89,4lm/W		180cd
		Blue	130lm	23,0lm/W		46cd
		Amber	592lm	105,0lm/W		217cd
		Meat	353lm	62,6lm/W	72,4	130cd

Distance/Lux table***

Distance	LED-Strip M12-250	LED-Strip M12-500
0,5m	272lx	544lx
1m	68lx	136lx
2m	17lx	34lx

* Luminous flux is measured after at least 60 seconds of power-on time. Measuring is according according to DIN 5032-1 (1999) „Light measurement Photometric methods“ 9.5.4 „[luminous flux] determination with a sphere photometer according to Ulbricht“. Sphere diameter is 1000mm. Comparison lamp is a halogen lamp. The system has been calibrated in a laboratory accredited to DIN17025.

** Spectrum and intensity are measured after a minimum of 60 seconds of power-on time. Measuring is according to CIE127 (2007) “Measure of LEDs” 4.3 “averaged LED intensity – condition B” by means of a cooled high-end “Back Illuminated” CCD spectrometer with a fibre optic probe based on an Ulbricht sphere with 25mm inner diameter and 1cm² measurement port. The system has been calibrated in a DIN17025-accredited laboratory.

*** The values are measured with a LED strip M12-250 and M12-500 in the colour temperature 6500K (others on request).

Regarding the measurements, it's a matter of actual measurements. Due to the typical LED manufacturing tolerance deviations may occur. Each individual product may vary from this data. We reserve the right of error and technical modifications.

Light distribution curves

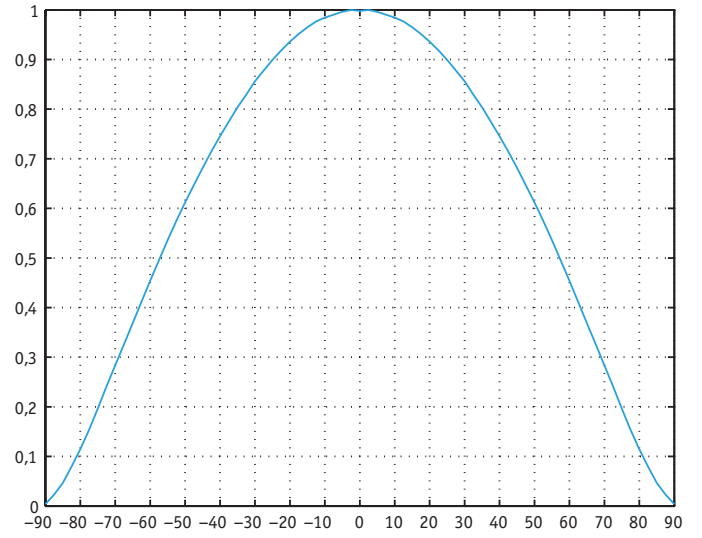
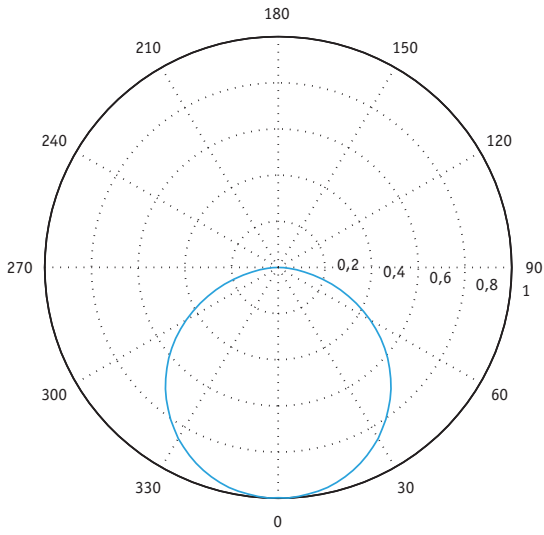

Binning (3Step MacAdam)

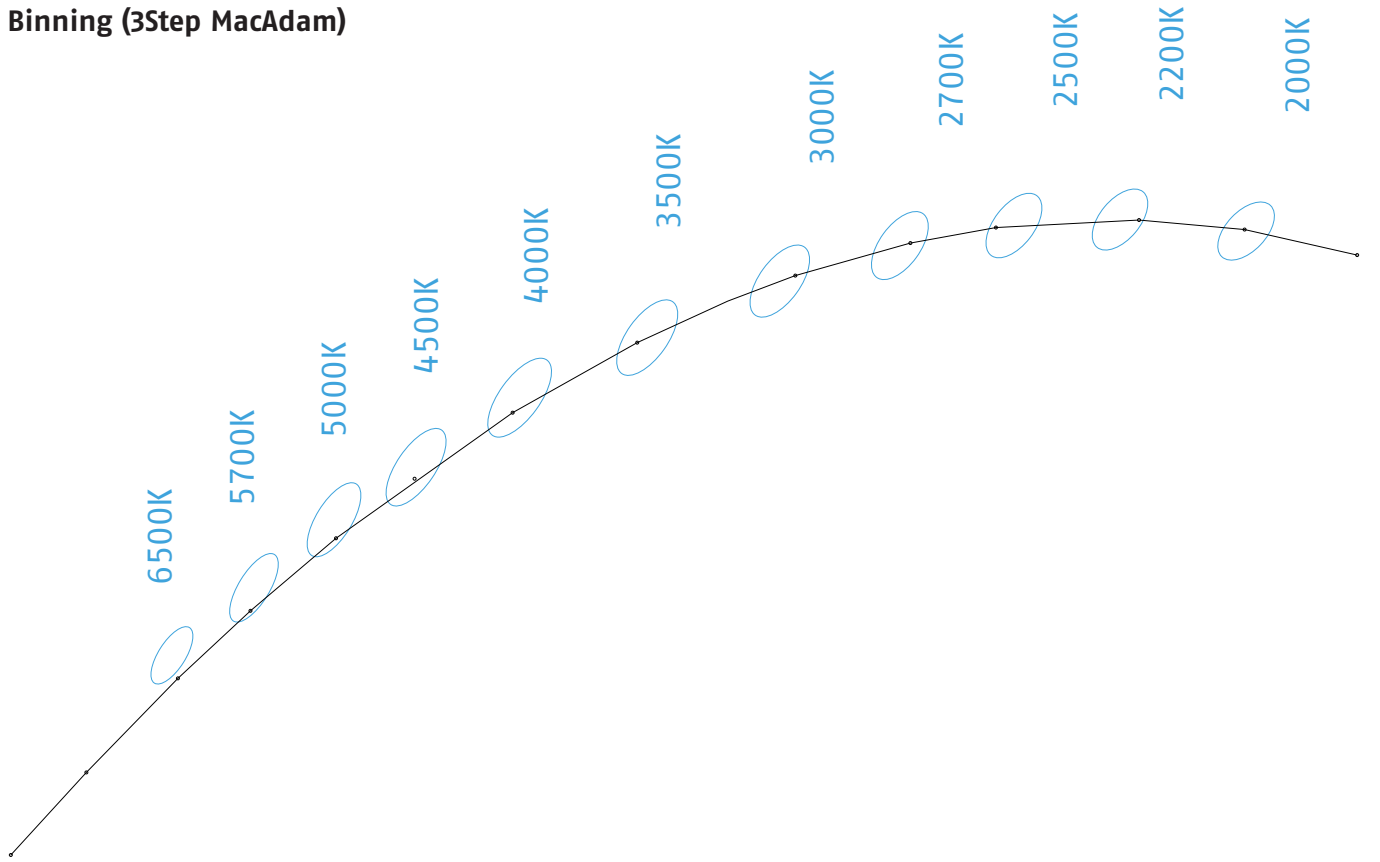

Spectral distribution

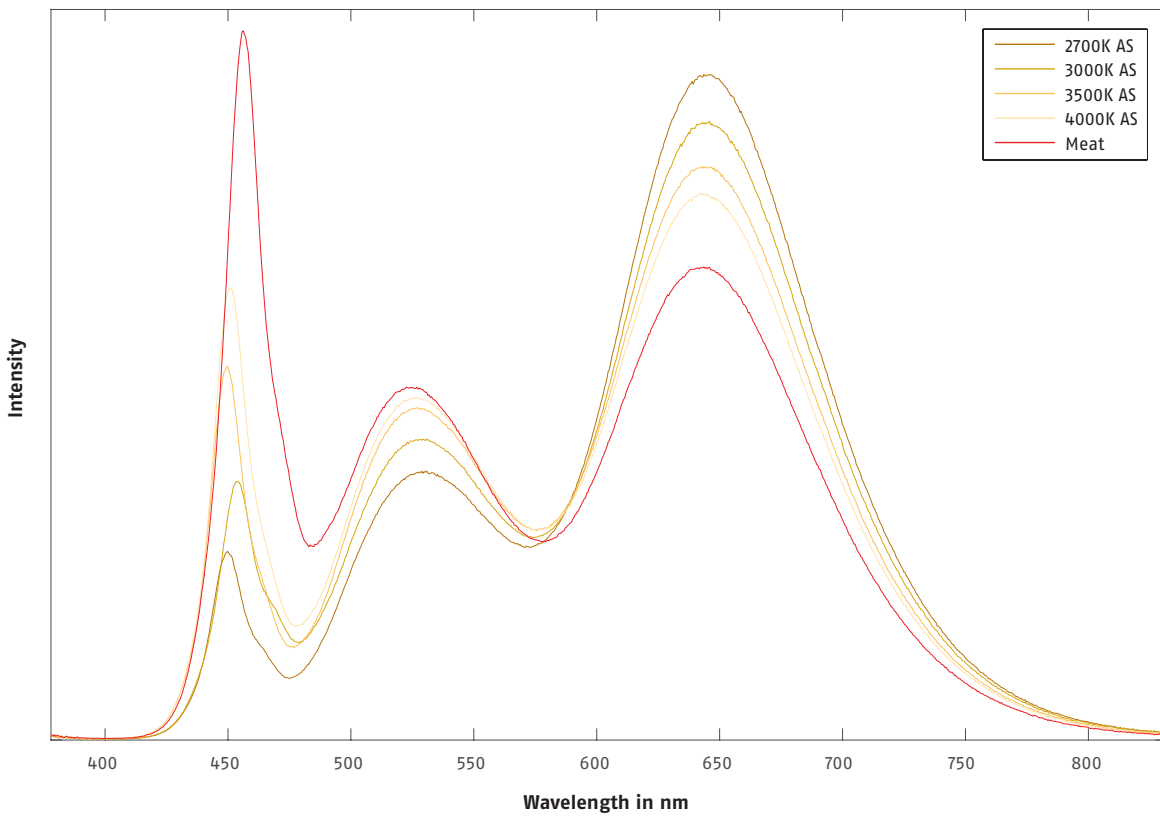
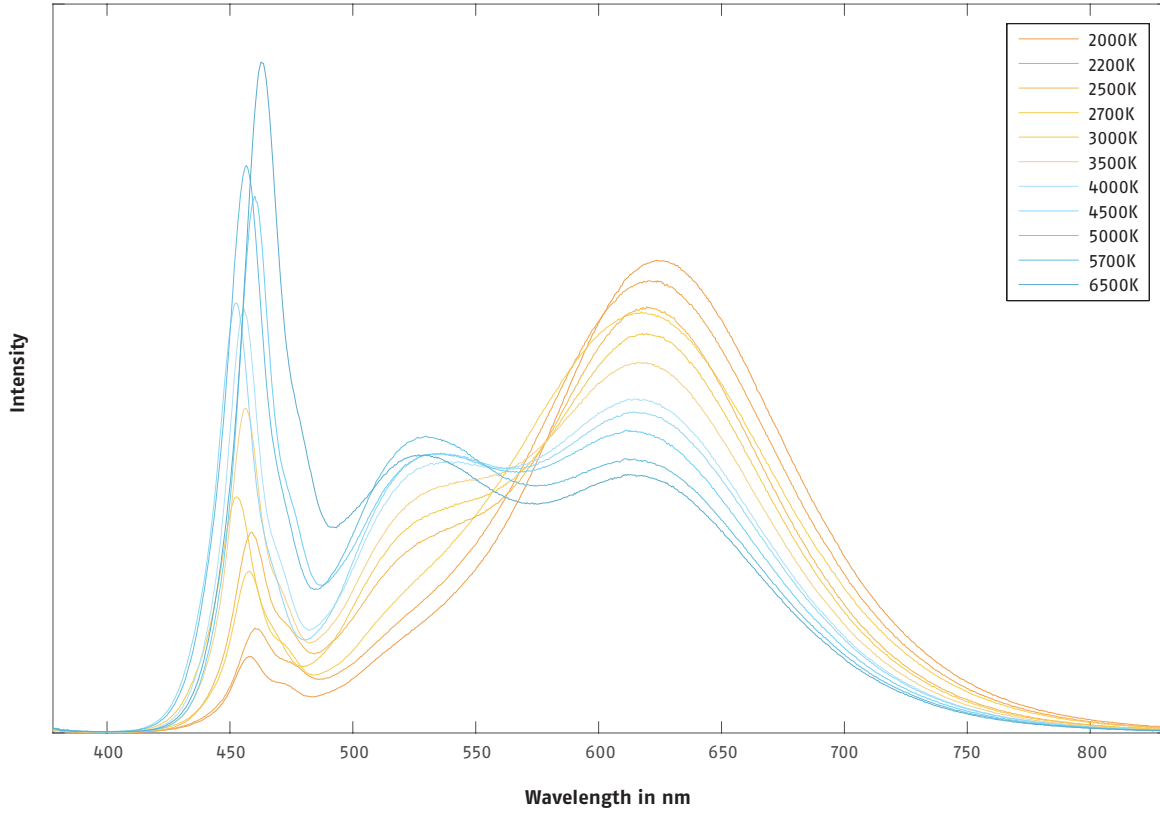

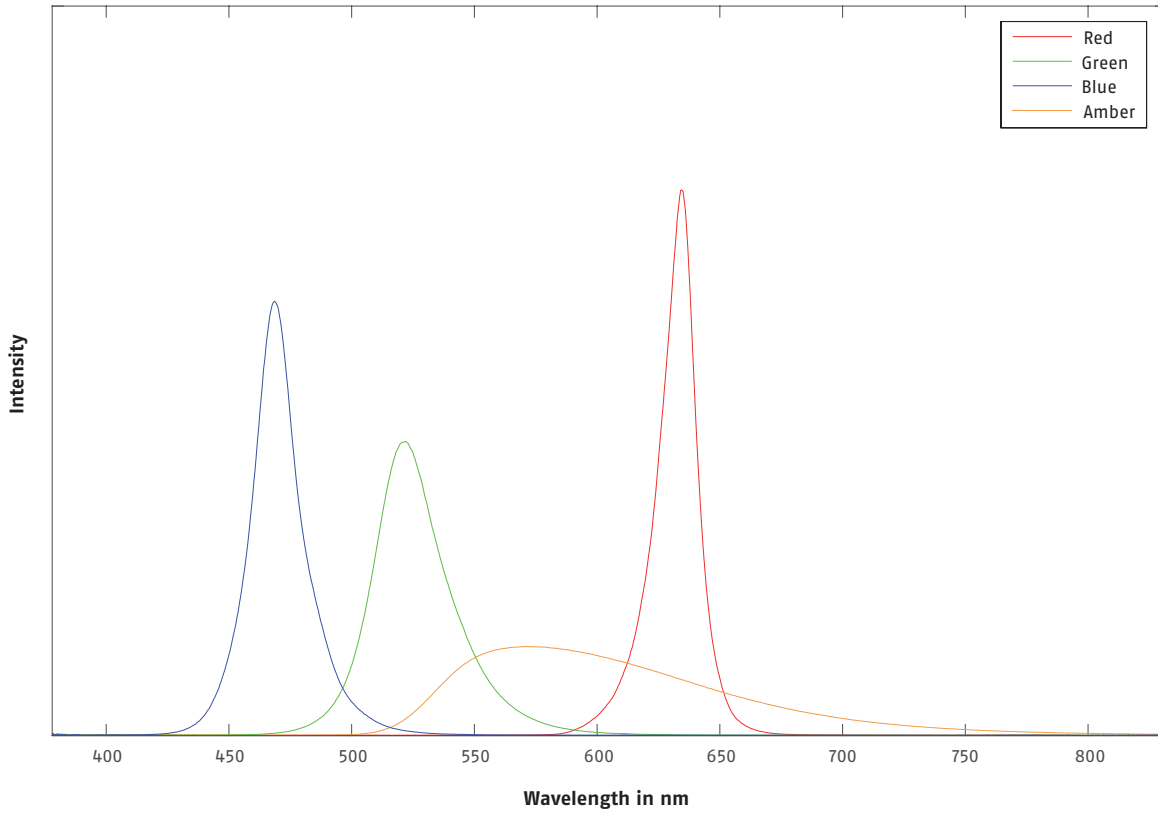

Electrical data

Features	LED-Strip M12-250	LED-Strip M12-500
Voltage range	20-24V	20-24V
Current (I_{max})	0,15A	0,3A

Pin Connection

System connector red

1	■	GND
2	■	DMX -
3	■	DMX +
4	■	24 V

Control options for LED-Strip M12

System Power Supply 4E



	LED-Strip M12-250	LED-Strip M12-500
DMX 512*	maximum 100 LED-Strips per controller maximum 25 LED-Strips per XLR output maximum 20 LED-Strips per System connector red	maximum 48 LED-Strips per controller maximum 12 LED-Strips per XLR output maximum 10 LED-Strips per System connector red
DPB**	maximum 160 LED-Strips per controller maximum 40 LED-Strips per XLR output maximum 20 LED-Strips per System connector red	maximum 80 LED-Strips per controller maximum 20 LED-Strips per XLR output maximum 10 LED-Strips per System connector red

*channel-restricted

**current limited

Cabling example System Power Supply 4E with LED-Strip M12

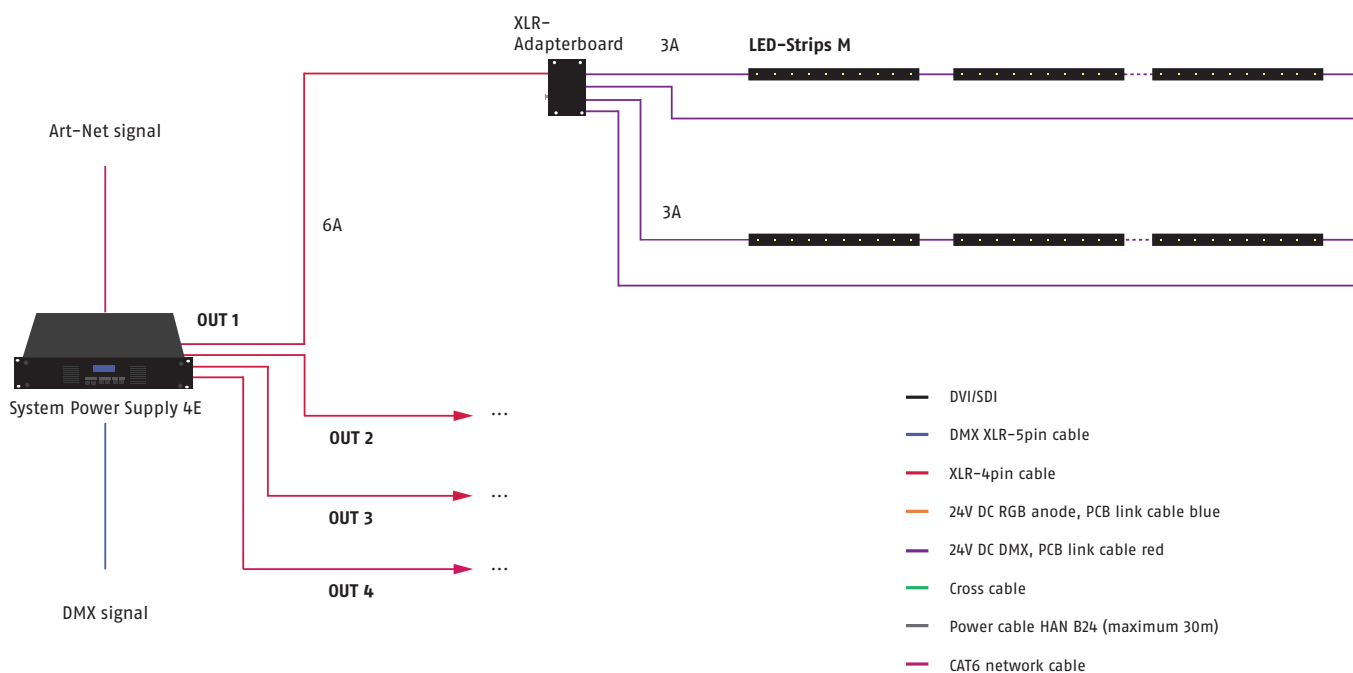

DPB Pixel-Router Pro

Specific feature: fanless operation at normal load



	LED-Strip M12-250	LED-Strip M12-500
DMX 512*	maximum 100 LED-Strips per controller maximum 25 LED-Strips per output maximum 20 LED-Strips per System connector red	maximum 48 LED-Strips per controller maximum 12 LED-Strips per output maximum 10 LED-Strips per System connector red
DPB**	maximum 160 LED-Strips per controller maximum 40 LED-Strips per output maximum 20 LED-Strips per System connector red	maximum 80 LED-Strips per controller maximum 20 LED-Strips per output maximum 10 LED-Strips per System connector red

*channel-restricted
**current limited

Cabling example DPB Pixel-Router Pro with LED-Strip M12

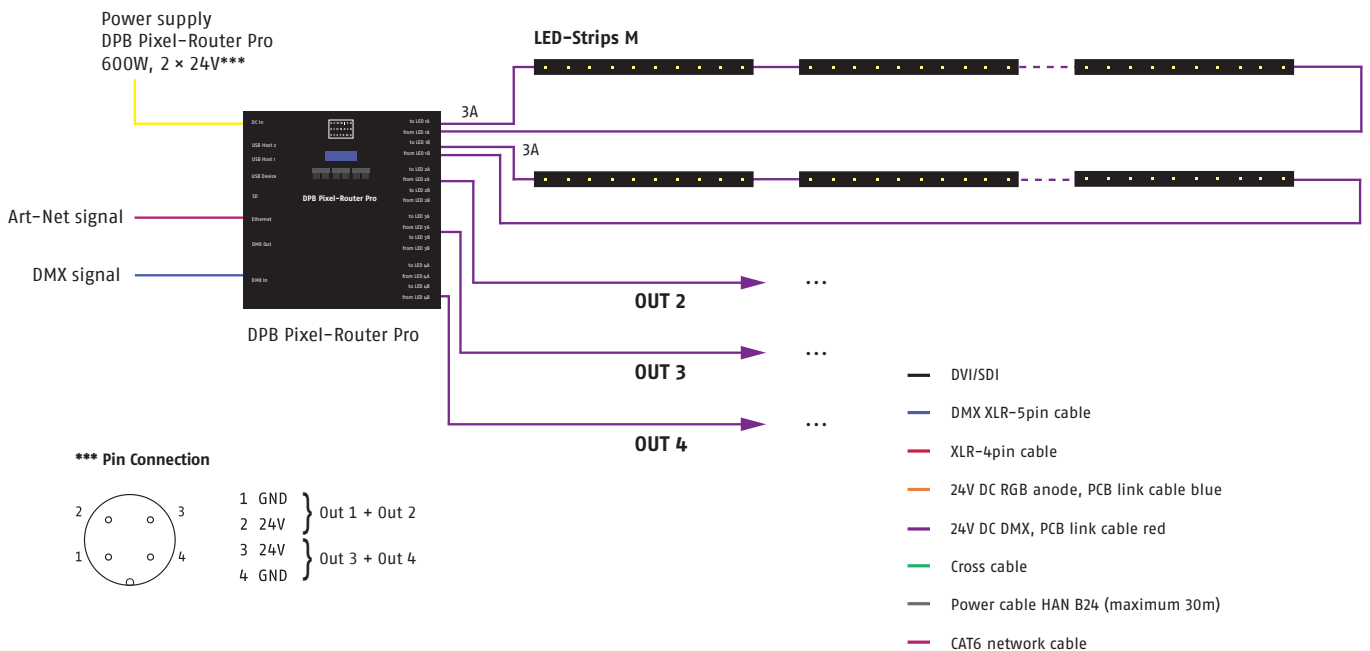

DPB Pixel-Router



	LED-Strip M12-250	LED-Strip M12-500
DPB	maximum 80 LED-Strips per controller maximum 20 LED-Strips per output	maximum 40 LED-Strips per controller maximum 10 LED-Strips per output

Cabling example DPB Pixel-Router with LED-Strip M12

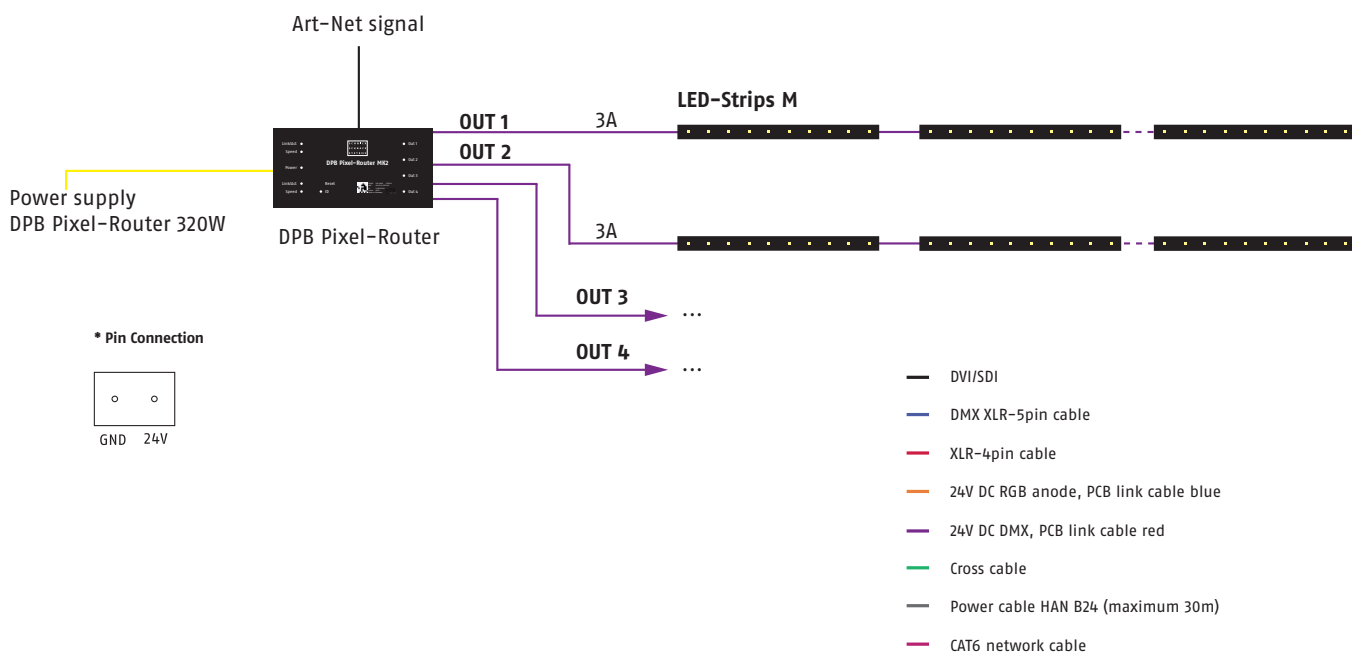

Sys One

Specific feature: fanless operating



LED-Strip M12-250

Power Data Out	DMX 512
Output XLR-4pin	maximum 25 LED-Strips per controller
Output System connector red (2 universes)	maximum 40 LED-Strips per controller maximum 20 LED-Strips per system connector red

LED-Strip M12-500

Power Data Out	DMX 512
Output XLR-4pin	maximum 12 LED-Strips per controller
Output System connector red (2 universes)	maximum 20 LED-Strips per controller maximum 10 LED-Strips per system connector red

Please note: connect only one output variable (XLR-4pin or System connector red)!

Cabling example Sys One (XLR-4pin connector) with LED-Strip M12

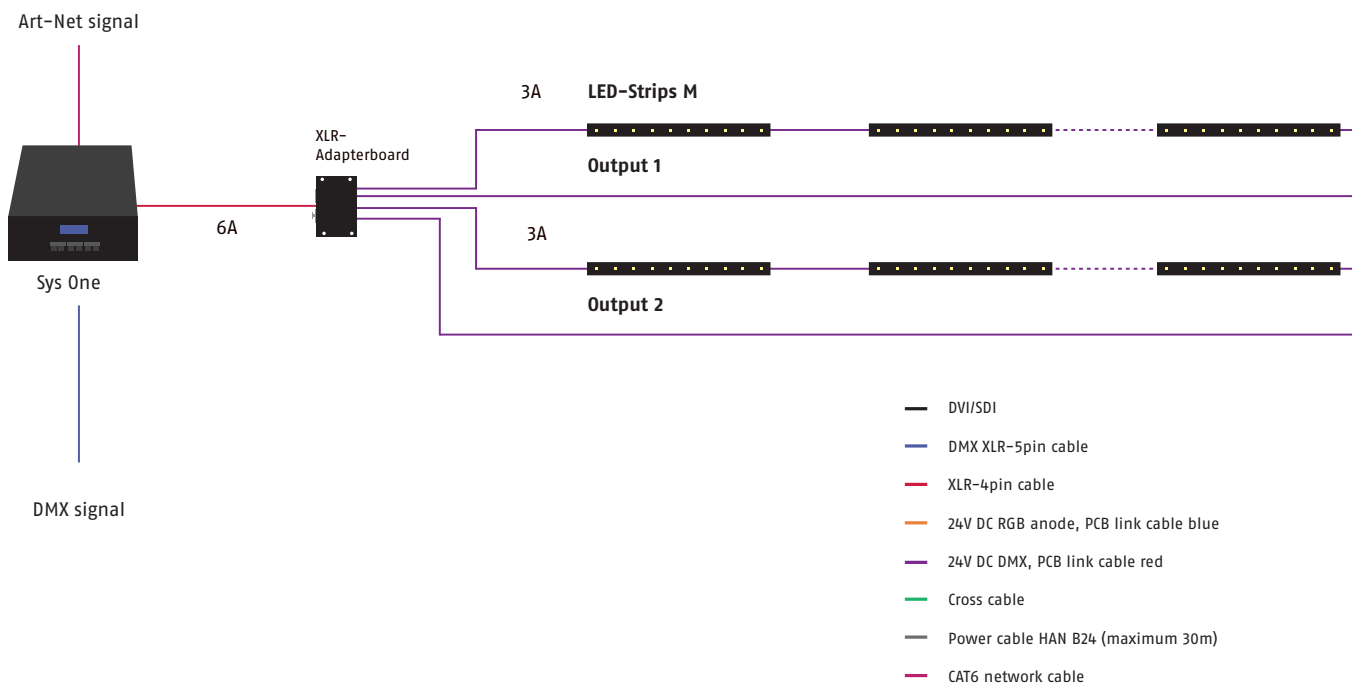

Cabling example Sys One (System connector red) with LED-Strip M12

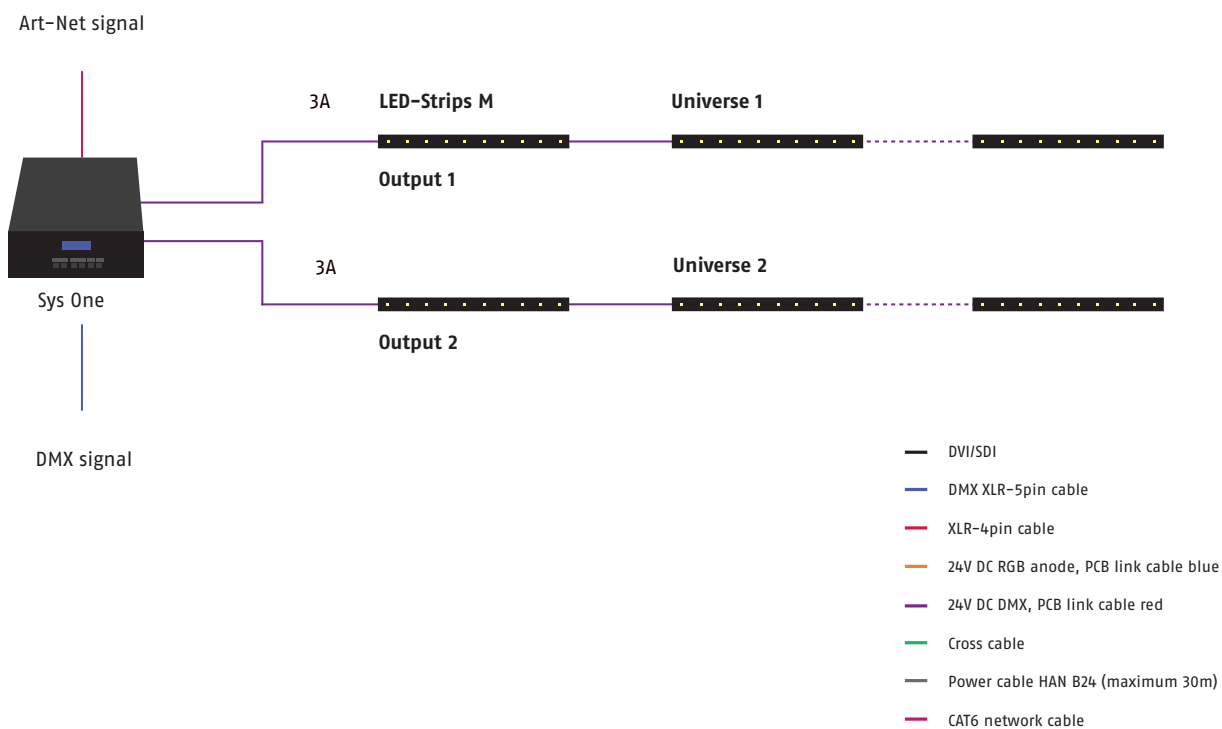

70W power supply with DMX



LED-Strip M12-250

maximum 20 LED-Strips per power supply

LED-Strip M12-500

maximum 10 LED-Strips per power supply

Cabling example 70W power supply with DMX

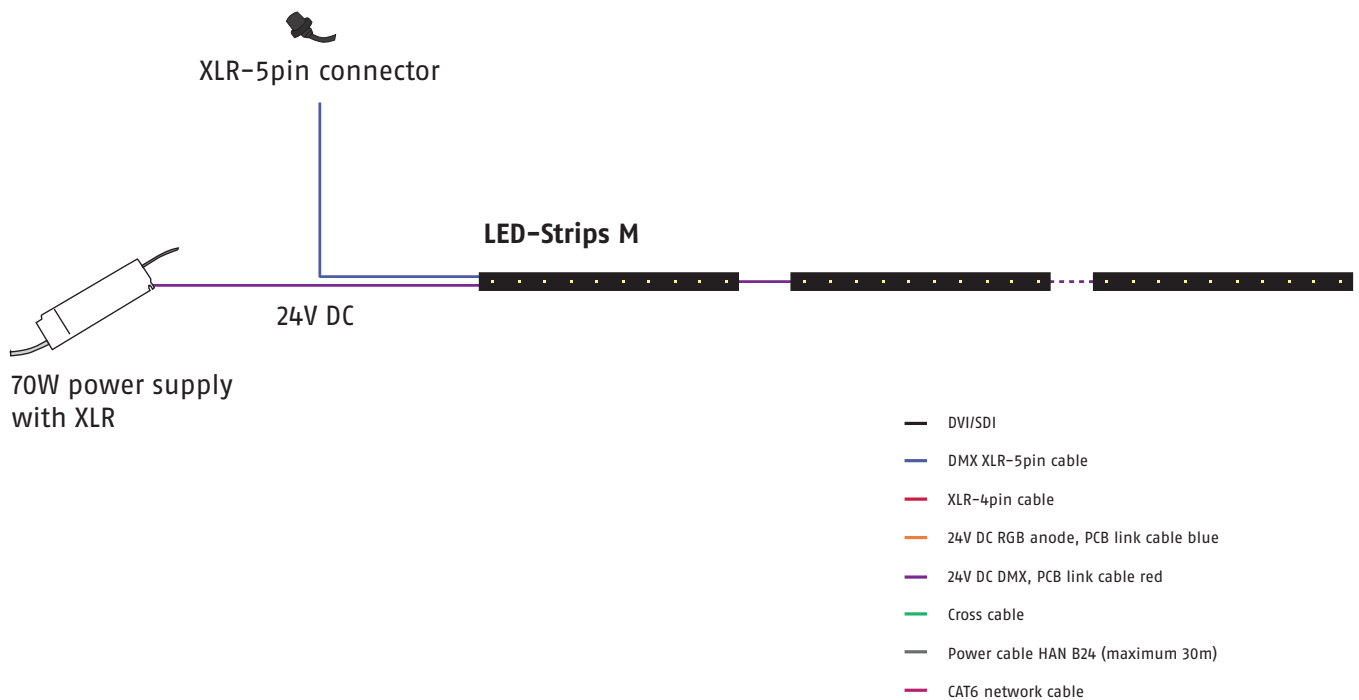

Mounting

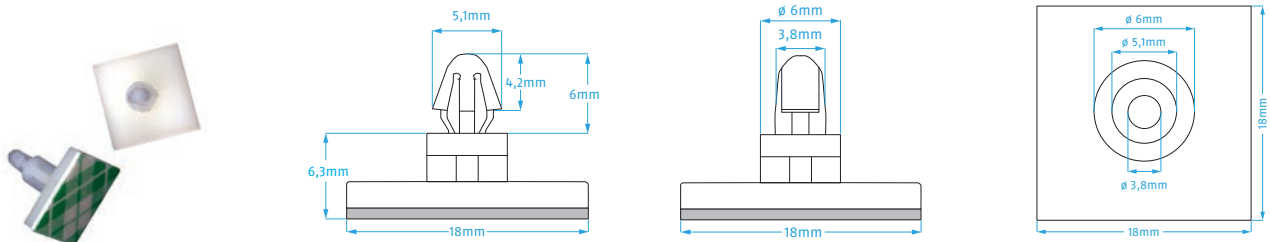

Description

PCB holder 6mm, self-adhesive version

Item number

802.0001

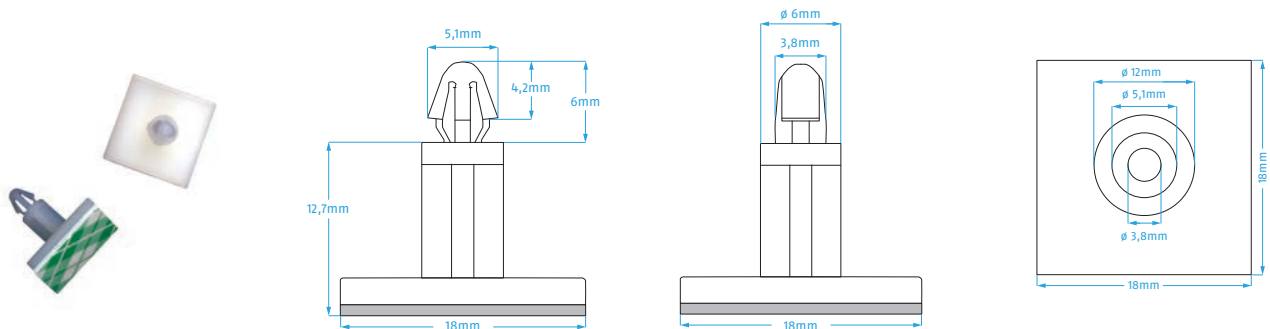

Description

PCB holder 12mm, self-adhesive version

Item number

802.0002

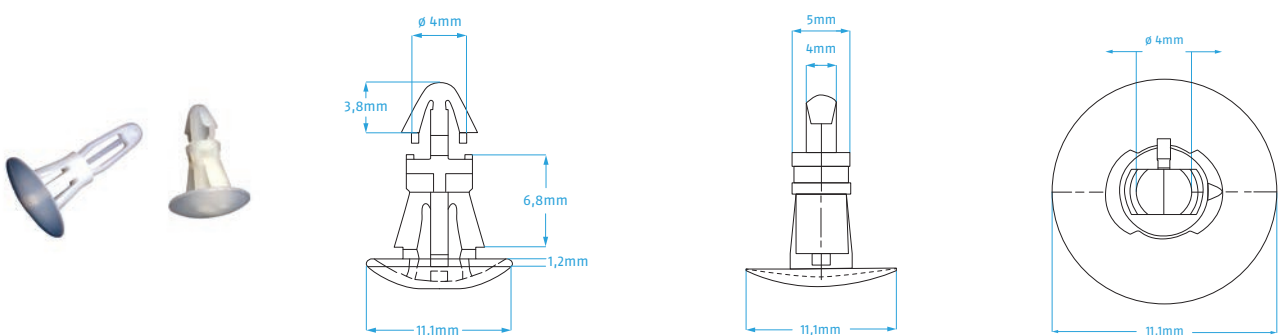

Description

PCB holder 6mm, plug-in version (for plates)

Item number

802.0003

Drill hole

5,4mm

Material thickness

1,5-1,6mm

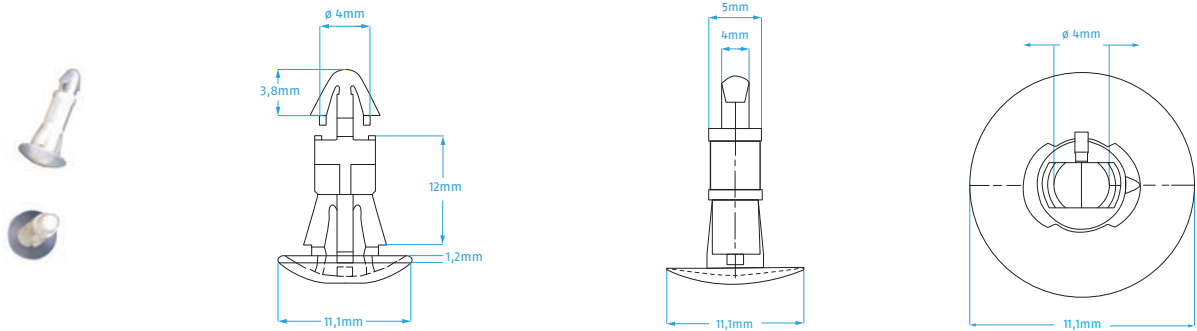

Description	Item number	Drill hole	Material thickness
PCB holder 12mm, plug-in version (for plates)	802.0004	5,4mm	1,5-1,6mm

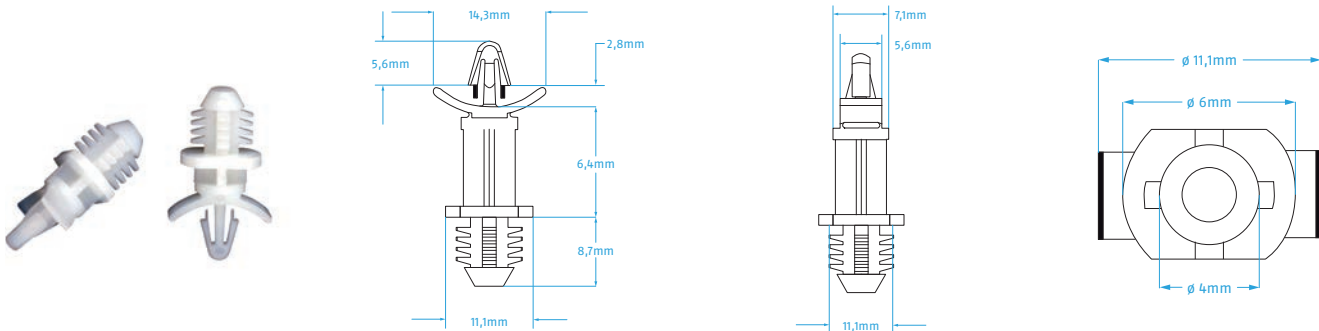

Description	Item number	Drill hole	Material thickness
PCB holder 6mm, drill version (for wood or plastic)	802.0006	7,9mm	minimum 6,4mm

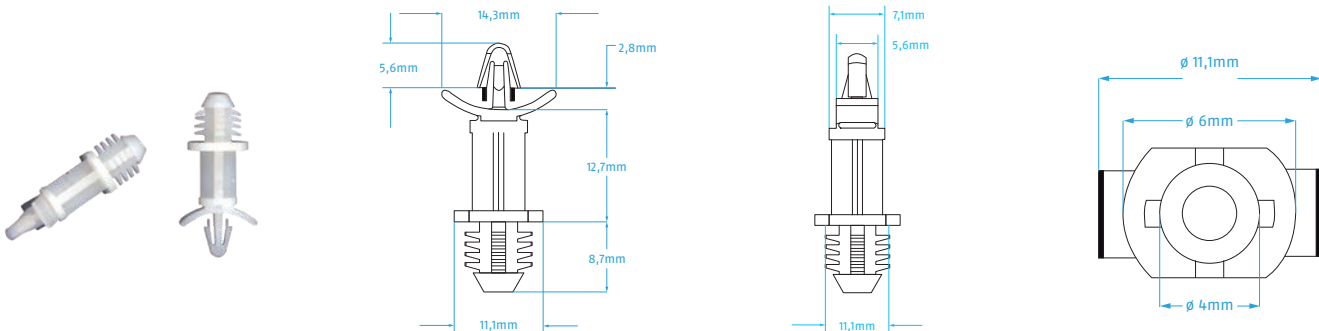

Description	Item number	Drill hole	Material thickness
PCB holder 12mm, drill version (for wood or plastic)	802.0007	7,9mm	minimum 6,4mm

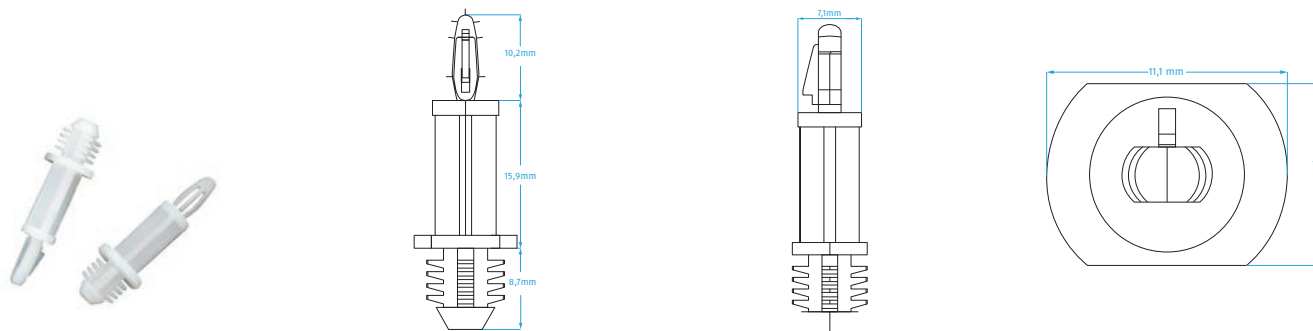

Description	Item number	Drill hole	Material thickness
PCB holder 16mm, drill version (for wood or plastic)	802.0008	7,9mm	minimum 6,4mm

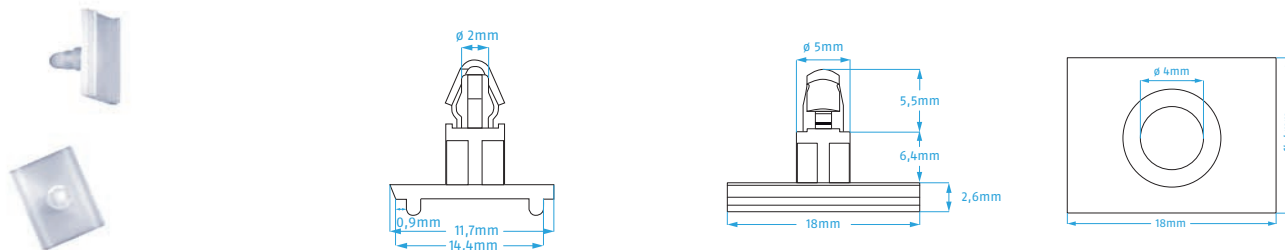

Description	Item number
PCB holder 6mm, plug-in version (for click-profile)	802.0009

Accessoires

Profil18

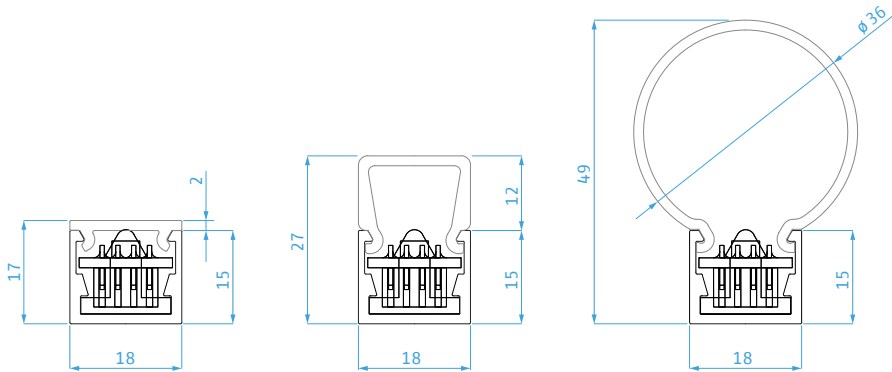

Aluminum profile	Article number
LED-Profil 18-15, aluminum black, 2m*	804.3201
LED-Profil 18-15, aluminum anodized, 2m*	804.3203
Low quantity surcharge < 10 pieces	804.9999

Diffusers	Article number
Diffuser 18-02, satin, 2m, for all Pixel distances*	804.3226
Diffuser 18-12, white, 2m, for 12mm Pixel distance or less*	804.3228
Diffuser 18-12, black, 2m, for all Pixel distances*	804.3230
Diffuser 18-D36, white, 2m, for 25mm Pixel distance or less*	804.3232

Head ends	Article number
Head end 18-02, black, professional 3D print	804.3251
Head end 18-12, black, professional 3D print	804.3261
Head end 18-D36, black, professional 3D print	804.3271

* Special lengths and colours available upon request. For special colours please provide relevant RAL-information.

** For a homogeneous surface representation.

Rectangular profiles



Rectangular profiles	Item number
Rectangular profile, 2m, 24mm × 30mm (W × H), aluminium anodised*	804.2401
Rectangular profile, 2m, 24mm × 30mm, aluminium anodised, in pack of ten	804.2411
Rectangular profile, 2m, 24mm × 30mm (W × H), black*	804.2403
Rectangular profile, 2m, 24mm × 30mm (W × H), black, in pack of ten	804.2413

Click profile	Item number
Click eachfile for rectangular profile, 2m, transparent	802.0040
Click eachfile for rectangular profile, 2m, in pack of ten	802.0041

Brackets	Item number
Bracket for rectangular profile, 2m, plastic, black	804.2492
Bracket for rectangular profile, 2m, plastic, black, in pack of ten	804.2493

Head ends	Item number
Head end aluminium anodised, 6mm, including screws	804.2431
Head end aluminium anodised, 12mm, including screws	804.2441
Head end black, lacquered, 6mm, including screws	804.2433
Head end black, lacquered, 12mm, including screws	804.2443

Cylindrical profiles

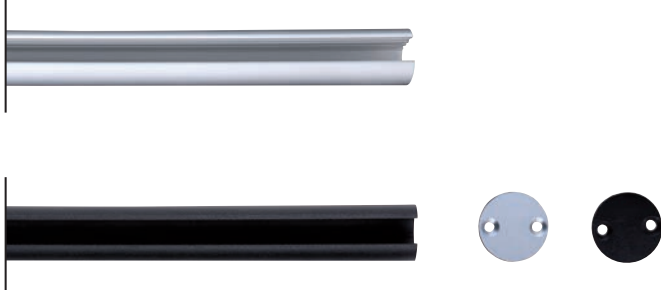

Cylindrical profiles	Item number
Cylindrical profile, 2m, \varnothing 25mm, aluminium anodised*	804.2504
Cylindrical profile, 2m, \varnothing 25mm, black*	804.2506

Bracket	Item number
Bracket for cylindrical profile (transparent)	802.0038
Bracket for cylindrical profile (black)	802.0039

Covering	Item number
Covering for cylindrical profile 2m, transparent	804.2594

Head ends	Item number
Head end aluminium natural, lasered, 2mm thin, including screws	804.2520
Head end aluminium, rotated, anodised, 12mm width, including screws	804.2541
Head end aluminium, rotated, anodised, 12mm width, with cable outlet, including screws	804.2551
Head end black, lasered, 2mm thin, including screws	804.2523
Head end black, rotated, 12mm width, including screws	804.2543
Head end black, rotated, 12mm width, with cable outlet, including screws	804.2553

* Special lengths and colours available upon request. For special colours please provide relevant RAL-information.

Lenses



1 Lens Spot (19°)



2 Lens Spot frost (30°)



3 Lenses Medium (35°)



4 Lenses Wide (45°)

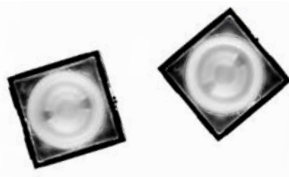

5 Lenses X-Wide (50°)



6 Oval Lenses (40° × 22°)

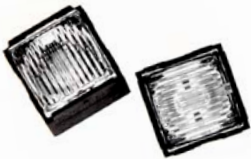

7 Oval Lenses (22° × 40°)

	Lens type	Item number
Lens Spot (19°) for LED-Strip M12 MK3 1	Ledil Larisa-RS-Pin	720.0001
Lens Spot frost (30°) for LED-Strip M12 MK3 2	Ledil Larisa-RZ-Pin	720.0002
Lenses Medium (35°) for LED-Strip M12 MK3 3	Ledil Larisa-M-Pin	720.0003
Lenses Wide (45°) for LED-Strip M12 MK3 4	Ledil Larisa-W-Pin	720.0004
Lenses X-Wide (50°) for LED-Strip M12 MK3 5	Ledil Larisa-VVW-Pin	720.0005
Oval Lenses (40° × 22°) for LED-Strip M12 MK3 6	Ledil Larisa-O-Pin	720.0006
Oval Lenses (22° × 40°) for LED-Strip M12 MK3 7	Ledil Larisa-O-90-Pin	720.0007

Lenses cannot be used with PCB holders.

Order numbers

	LED-Pitch	Length	Channels	Power (I_{max})	Connection	Colour	Item number
LED-Strip M12-250	12,5mm	250mm	20	0,15A	System connector red	2000K	104.0006
						2200K	104.0008
						2500K	104.0010
						2700K	104.0012
						2700K AS	104.0014
						3000K	104.0016
						3000K AS	104.0018
						3500K	104.0020
						3500K AS	104.0022
						4000K	104.0024
						4000K AS	104.0026
						4500K	104.0028
						5000K	104.0030
						5700K	104.0032
						6500K	104.0034
						Rot	104.0036
						Grün	104.0038
						Blau	104.0040
						Amber	104.0042
						Meat	104.0044
						Multicoloured	104.0046

	LED-Pitch	Length	Channels	Power (I_{max})	Connection	Colour	Item number
LED-Strip M12-500	12,5mm	500mm	40	0,3A	System connector red	2000K	104.0005
						2200K	104.0007
						2500K	104.0009
						2700K	104.0011
						2700K AS	104.0013
						3000K	104.0015
						3000K AS	104.0017
						3500K	104.0019
						3500K AS	104.0021
						4000K	104.0023
						4000K AS	104.0025
						4500K	104.0027
						5000K	104.0029
						5700K	104.0031
						6500K	104.0033
						Rot	104.0035
						Grün	104.0037
						Blau	104.0039
						Amber	104.0041
						Meat	104.0043
Multicoloured	104.0045						
Shorten from 500mm to 262,5mm							104.9981
Shorten from 500mm to 275mm							104.9982
Shorten from 500mm to 287,5mm							104.9983
Shorten from 500mm to 300mm							104.9984
Shorten from 500mm to 312,5mm							104.9985
Shorten from 500mm to 325mm							104.9986
Shorten from 500mm to 337,5mm							104.9987
Shorten from 500mm to 350mm							104.9988
Shorten from 500mm to 362,5mm							104.9989
Shorten from 500mm to 375mm							104.9990
Shorten from 500mm to 387,5mm							104.9991
Shorten from 500mm to 400mm							104.9992
Shorten from 500mm to 412,5mm							104.9993
Shorten from 500mm to 425mm							104.9994
Shorten from 500mm to 437,5mm							104.9995
Shorten from 500mm to 450mm							104.9996
Shorten from 500mm to 462,5mm							104.9997
Shorten from 500mm to 475mm							104.9998
Shorten from 500mm to 487,5mm							104.9999

	Operating voltage	Power (I_{max})	Channels	Input	Output	Item number
System Power Supply 4E	110-240V AC	4 × 6A*	4 × 3072 channels (DPB) 4 × 512 channels (DMX)	Ethercon RJ 45 XLR-5pin IN/Through	4 × XLR-4pin	203.0003
DPB Pixel-Router MK2.6	24V DC	4 × 3A	4 × 3072 channels	RJ 45	4 × System connector red	203.0021
DPB Pixel-Router POE MK2.6	24V DC	4 × 3A	4 × 3072 channels	RJ 45	4 × System connector red	203.0022
DPB Pixel-Router Pro	100-240 V AC	4 × 2 × 3A	4 × 3072 channels (DPB) 4 × 512 channels (DMX)	Ethercon RJ 45 XLR-5pin IN/Through	System connector red, maximum 2 × 3A	203.0023
Sys One	110-240V AC	1 × 6A or 2 × 3A or 2 × (3 × 1A)	1 × 512** or 2 × 512**	XLR-5pin IN/Through	1 × XLR-4pin 2 × System connector red 2 × System connector blue	203.0007
70W-Power Supply (24V DC + DMX)***	220-240V AC	1 × 3A		XLR-5pin	1 × System connector red	204.0152

* Note: US version only 4 × 4A at 110V

** depending on the output configuration

*** not recommended for larger installations

ESD warning

Please be aware that electrostatic discharges can destroy LED boards, and our experience shows that this does happen. During assembly, we recommend wearing at least one antistatic wrist strap and avoiding static discharges – such as those that arise when removing protective film or dry cleaning acrylic glass, for example – near LEDs! Antistatic materials should be used when packaging the LED boards. Normal bubble wrap or other plastic bags are not suitable.

For reasons of safety and radio shielding, please only use systems we have approved to provide a power supply for our LED components. All technical information is based on the version at the time of printing.

We reserve the right to make technical specifications in terms of a product improvement without prior notice. Printing – even excerpts – requires the written consent of Schnick-Schnack-Systems GmbH.

Why Schnick Schnack Systems?

As installation times become increasingly shorter the complexity of systems simultaneously increases as do the requirements of customers.

We are a supplier who delivers high-quality reliable systems – under tight deadline constraints that are not only quick to install but also simple to operate and service.

Schnick-Schnack-Systems GmbH

Mathias-Brüggen-Straße 79
50829 Cologne (Germany)

Phone +49 (0) 221/99 2019-0
Fax +49 (0) 221/16 85 09-73

info@schnickschnacksystems.com
www.schnickschnacksystems.com